

SHEET METAL MICROMETERS

- Deep frame suitable for sheet metal, paper and plastic
- Graduation 0.01mm
- Ratchet stop
- Carbide measuring faces

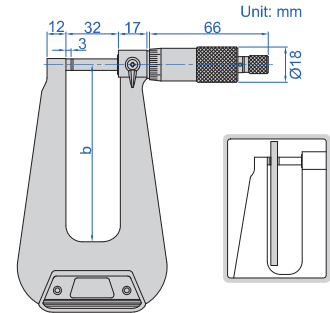

3239-253



Code	Range	Type	Accuracy	b
3239-253	0-25mm	A	7 μ m	155mm
3239-253F	0-25mm	B	7 μ m	155mm
3239-254F	0-25mm	B	10 μ m	310mm
3239-253S	0-25mm	C	7 μ m	155mm

