

## OUTSIDE MICROMETERS (STEEL PLATE FRAME)

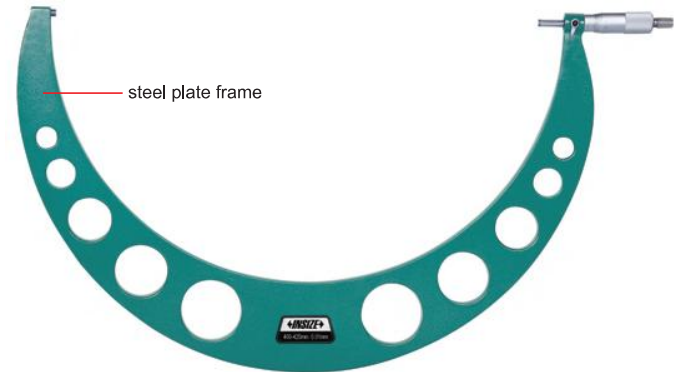
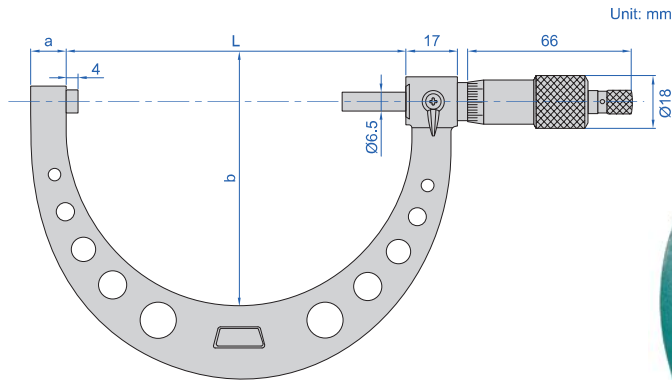

- Graduation: 0.01mm
- Carbide measuring faces
- Meet DIN863-1
- Ratchet stop
- Supplied with setting standards

3216-425

(mm)

Code	Range	Accuracy	L	a	b
3216-325	300-325mm	10 $\mu$ m	338	20	176
3216-350	325-350mm	10 $\mu$ m	364	20	192
3216-375	350-375mm	11 $\mu$ m	389	20	202
3216-400	375-400mm	11 $\mu$ m	414	20	217
3216-425	400-425mm	12 $\mu$ m	440	20	226
3216-450	425-450mm	12 $\mu$ m	465	20	241
3216-475	450-475mm	13 $\mu$ m	491	20	255
3216-500	475-500mm	13 $\mu$ m	516	20	268



setting standard (included)